



MAINTENANCE INSTRUCTIONS

VB-20 series

03-2022



www.tecval.es

C/Berlin, 1 Nave 4 Pol.Can Torrella
08233-VACARISSES
Barcelona (Spain)

VACARISSES, Monday, March 7, 2022

Mr. Joan Viñas (Technical Manager)

Mr. Joan Ferran (General Director)

Mr. Narcís Ferran (Sales Manager)

MAINTENANCE INSTRUCTIONS

VB-20 series

Manual Ball Valves

1. Open the valve.



2. Remove the valve handle.



3. Remove this bolt.



4. Loosen the remaining bolts.



5. Swing out the center body.



6. Remove O'ring and seats.



7. Remove packing nut.



8. Remove spring washer, gland and packing



9. Turn stem 90° and remove the ball.



10. Remove stem and stem bearings.



11. Remove stem bearings.



12. Insert and lubricate new stem bearings.



13. Insert stem and stem bearings.



14. Insert ball and turn stem 90°.



15. Lubricate and reassemble new O'ring and seats.



16. Turn body and insert new packing.



17. Fasten packing nut.



DN 15	10 Nm
DN 20	10 Nm
DN 25	12 Nm
DN 32	12 Nm
DN 40	13 Nm

18. Insert handle and nut.



19. Fasten handle and nut.



20. Insert the following bolt.

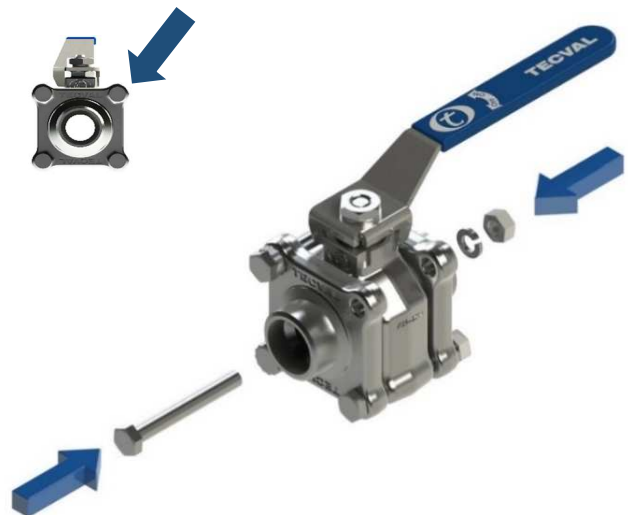

21. Torque body bolts.



Tightening order



	1 st pass	2 nd pass	3 rd pass
DN 15	0,5 Nm	3 Nm	10 Nm
DN 20	1 Nm	7 Nm	25 Nm
DN 32	2 Nm	10 Nm	35 Nm
DN 40	3 Nm	17 Nm	55 Nm

22. Purge the valve and system while still in open position and before cycling.

MAINTENANCE INSTRUCTIONS

VB-20 series

Actuated Ball Valves

1. Open the valve.



2. Remove these bolts.

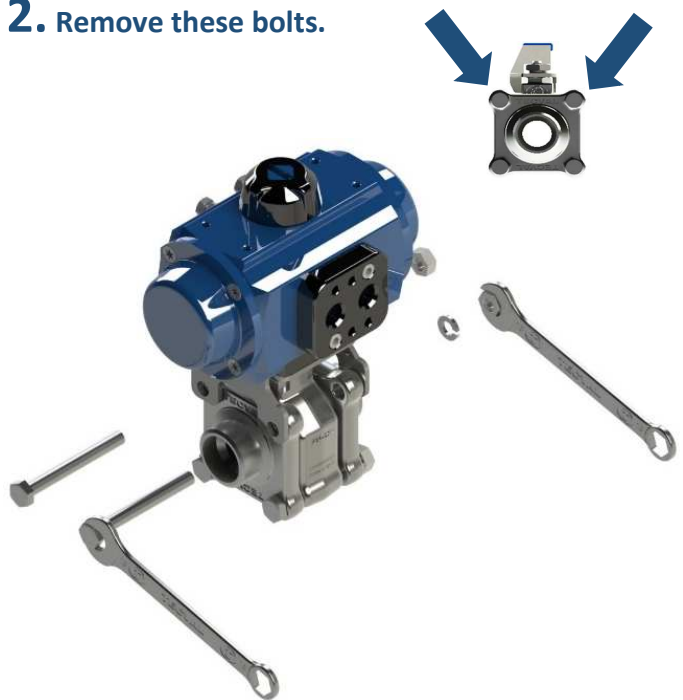

3. Remove actuator and connector.



4. Loosen the remaining bolts.



5. Swing out the center body.



6. Remove O'ring and seats.

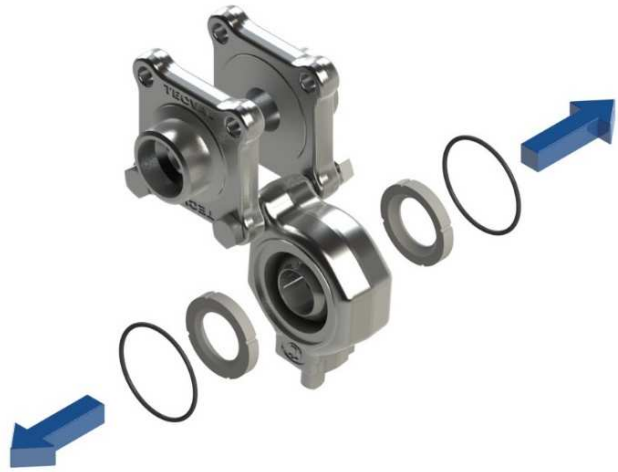

7. Remove packing nut.



8. Remove spring washer, gland and packing.



9. Turn stem 90° and remove the ball.



10. Remove stem and stem bearings.



11. Remove stem bearings.



12. Insert and lubricate new stem bearings.



13. Insert stem and stem bearings.



14. Insert ball and turn stem 90°.



15. Lubricate and reassemble new O' ring and Seats.



16. Turn body and insert new packing.



17. Fasten packing nut.



DN 15	10 Nm
DN 20	10 Nm
DN 25	12 Nm
DN 32	12 Nm
DN 40	13 Nm

18. Insert actuator and connector.



19. Insert the following bolts.



20. Torque body bolts.

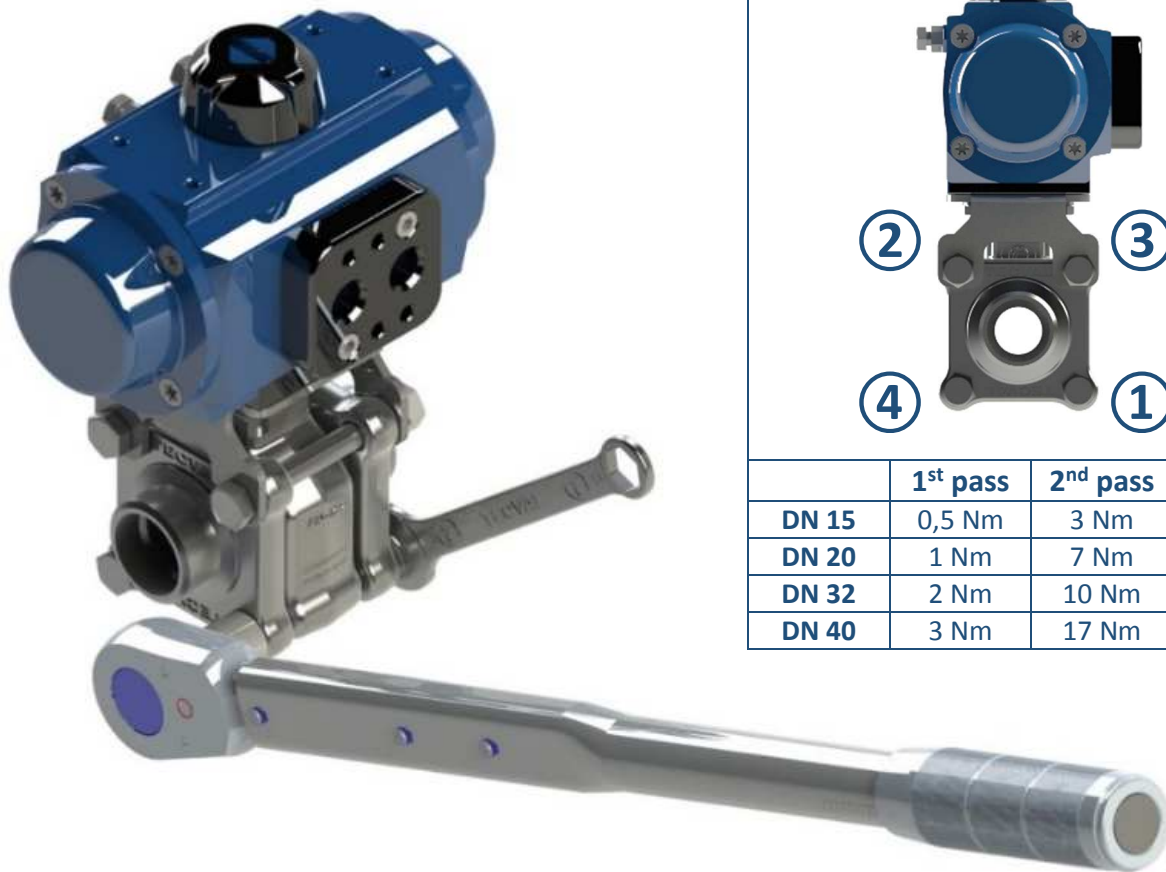

	1 st pass	2 nd pass	3 rd pass
DN 15	0,5 Nm	3 Nm	10 Nm
DN 20	1 Nm	7 Nm	25 Nm
DN 32	2 Nm	10 Nm	35 Nm
DN 40	3 Nm	17 Nm	55 Nm

21. Purge the valve and system while still in open position and before cycling.